

ZBTPU69000 DUAL

External Static Switch for ZDTAC60000 Dual Inverters

Features:

- Small size, light weight, standard 19" rack
- On-line/off-line configurations, user changeable during operation
- Fast switching, user programmable reaction time for optimized system performance
- Large user programmable synchronization range
- Continuous microprocessor based internal monitoring and diagnostics
- Remote monitoring through RS-232 with standard PC



User programmable parameters:

- On-line/Off-line configuration
- Minimum and maximum inverter RMS voltage conformity
- Minimum and maximum mains RMS voltage conformity
- Minimum and maximum mains frequency conformity
- Maximum allowed mains frequency change rate
- Load level to return to inverter supply after overload
- Delay to switch to inverters at rapid mains blackout or over voltage (min. 1ms)
- Delay to switch to mains at rapid inverter blackout or over voltage (min. 1ms)

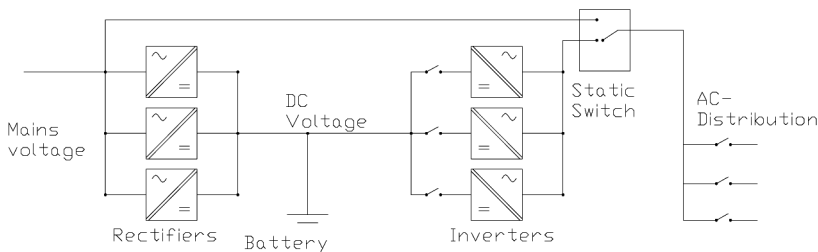

STATIC SWITCH (BYPASS) MODELS							
Type	Nominal Voltage	Frequency Range	Max Current	Nominal Power	Cooling	Dimensions Without Handles	Weight
ZBTPU69230FR	230VAC	40-70Hz	34A	7500VA	Forced, fan	220 x 64 x 409 mm	3 kg
ZBTPU69310FR	115VAC	40-70Hz	34A	3750VA	Forced, fan	220 x 64 x 409 mm	3 kg

19" 1.5U POWERFRAMES (sub-racks)	
Type	Description
ZMTR8180	Sub-rack for inverter and static switch, 19" x 1.5U x 435mm
ZMTBP68300	Sub-rack including manual bypass and position for static switch (separate datasheet)
ZMTBP68360	Sub-rack including manual bypass, AC-distribution and position for static switch, see separate datasheet for fuse types
Z8T169274A	Coverplate set for empty module space in 19" 1.5U subrack

Specification

Electrical:

Operation voltage range
Synchronizing frequency range
Protection
Efficiency at full load

80 - 270 VAC
40-70 Hz (user programmable)
external fuse in mains AC input
> 99 % @ 230VAC

Mechanical:

Connectors in modules rear panel
Connectors in ZMTR8180 power frame rear panel

plug-in connectors DIN41612 F48, DIN41612 H15
Screw terminals. Crimped ring terminal for cable end.
AC in and AC out (Lin, Lout, N) and GND M5 screw terminals
Connectors are shielded from hazardous contact
Steel casing IP20
0...45°C full power
45...60°C reduced power

Enclosure
Environmental temperature

Standards:

Safety
EMC
2511

EN 60950-1
EN 55022B, EN61000-6-3, EN61000-6-1, ETS 300 132-2, BTNR

Alarms and Indicators:

LED indications

Overload – Fault - Mains failure - Mains in use - Inverter failure -
Inverter in use – Synchronized - Communication
Fault in system
Primary supply failure

Relay alarms

Remote monitoring through RS-232

Manual bypass and AC-Distribution Solutions

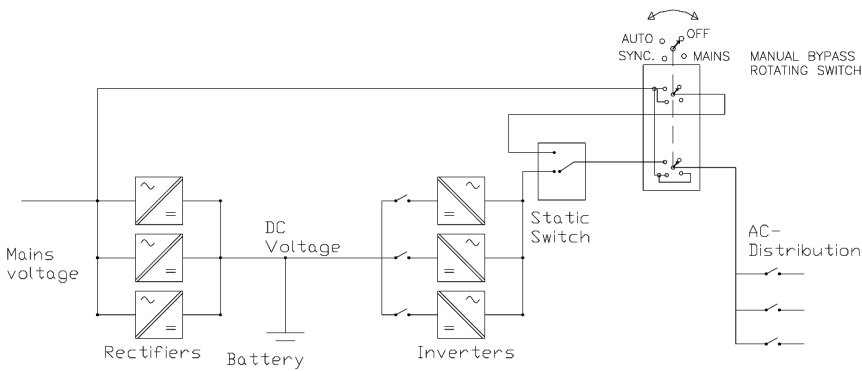

Standard modules
Ready made AC-distribution and manual bypass solutions to build full inverter systems just by choosing needed modules.

Customised solutions
Customised distribution solutions are also available based on project needs.



Complete Inverter System

ZMTBP68300 fits ideally to be used with ZDTAC60000 Dual 19" 1.5U inverters. Up to 6pcs of 1500VA inverters max 7.5kVA n+1 can be installed in parallel including external static switch, manual bypass and AC-distribution. ZMTBP68300 and inverters are installed on top of each other in 19" cabinet



ZITEC320 Distribution solutions

19" 1U distibution panels with ZITEC320 connectors offers safe and easily changeable distribution solution. Ampere meter also available for local load monitoring.