

# Inverter

## ZMTBP68000 Series

### AC-distribution and Manual Bypass for ZDTAC60000 Inverters

#### Complete Inverter System

Complete inverter system including 1...4pcs of inverters (600...4800VA), 6kVA static switch, manual bypass and AC-distribution can be installed to one 19" 6U sub-rack.



#### Modular Construction

6U/14TE Mechanics and connectors

Manual bypass switch

AC-distribution for 3 MCBs

MCB types can be selected

Due to modular construction the unit can include only manual bypass or AC-distribution or both of these features



Voltage 100...240VAC

Power rating 6 kVA, max 30A

4 pole manual bypass rotating switch

6mm<sup>2</sup> or 10mm<sup>2</sup> screw terminals for mains in and load, 90cm cables for static switch, see details next page

#### System level connection circuit:

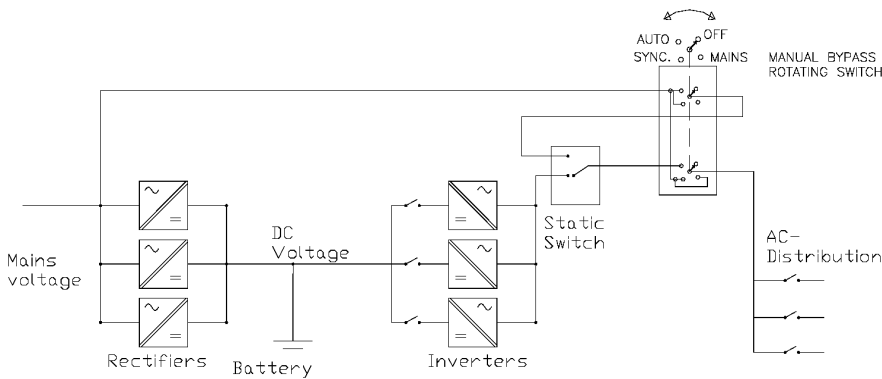

Manual bypass switch positions:

OFF

No supply

MAINS

Mains supply

No mains input for static switch

SYNC

Mains supply

Mains input connected to static switch

AUTO

Inverter System supply

#### MANUAL BYPASS AND AC-DISTRIBUTION TYPE NUMBERS

Type	Description
ZMTBP68000	Manual bypass 6kVA, max 30A, 14TE/6Ux160mm
ZATDU68030	AC Distribution unit for 3 pcs of output MCBs, 14TE/6Ux160mm Select MCBs from table below, any combination is possible
ZMTBP68060	Manual bypass 6kVA and AC Distribution unit for 3 pcs of output MCBs, 14TE/6Ux160mm Select MCBs from table below, any combination is possible

#### MCB ALTERNATIVES FOR ZATDU68030 OR ZMTBP68060

Type	Description	Type	Description
Z5T4100200	2A C-curve output MCB	Z5T4101001	10A B-curve output MCB
Z5T4100400	4A C-curve output MCB	Z5T4101601	16A B-curve output MCB
Z5T4100601	6A B-curve output MCB	Z5T4102001	20A B-curve output MCB
Z5T4100600	6A C-curve output MCB	Z5T4102501	25A B-curve output MCB

## ZMTBP68000 CONNECTION CIRCUIT AND PIN CONFIGURATION

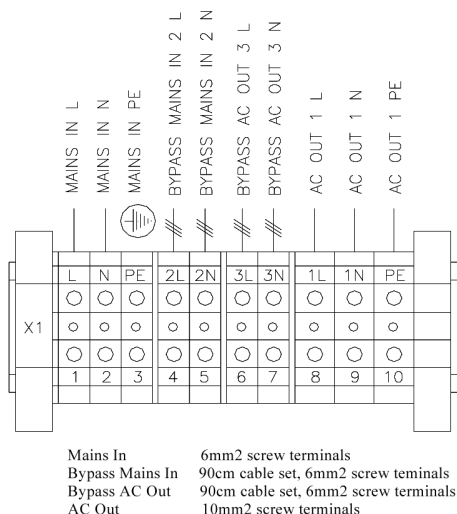
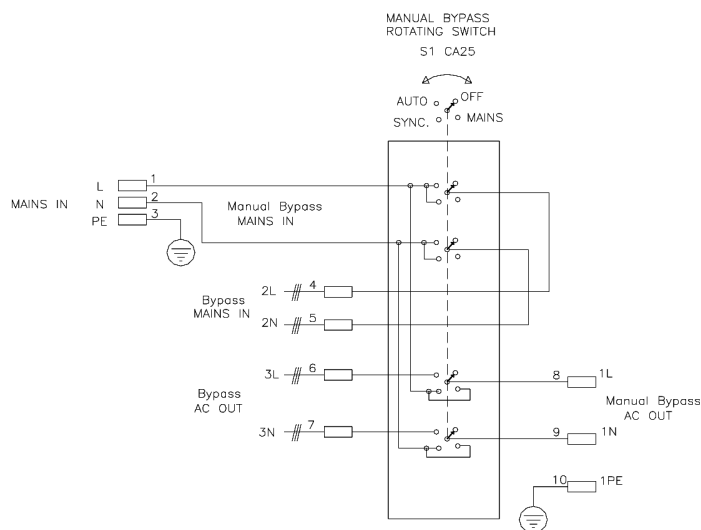

## ZATDU68030 CONNECTION CIRCUIT AND PIN CONFIGURATION

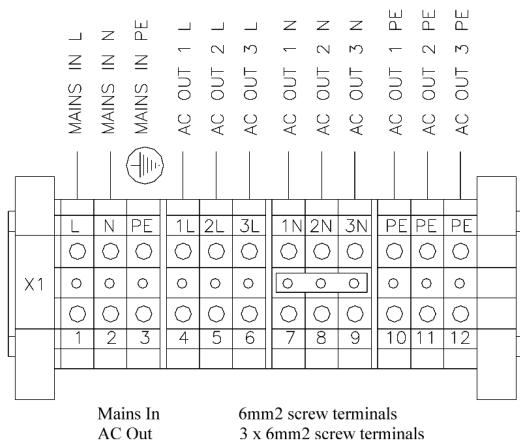
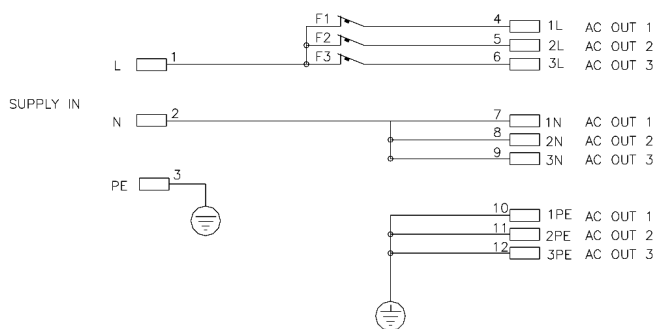

## ZMTBP68060 CONNECTION CIRCUIT AND PIN CONFIGURATION

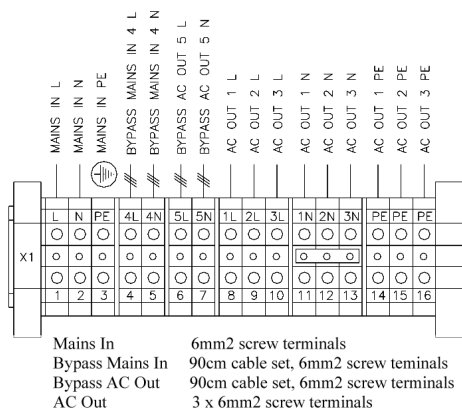
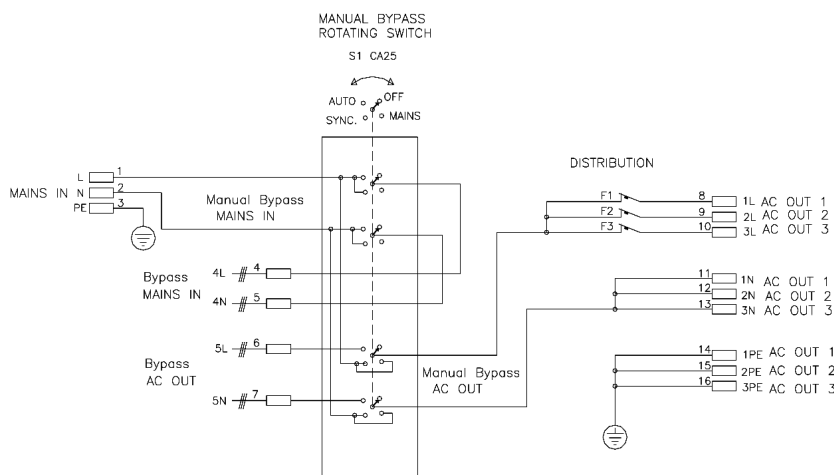

### MANUAL BYPASS SWITCH POSITIONS

- OFF No supply
- MAINS Mains supply, no mains input for static switch
- SYNC Mains supply, mains input connected to static switch
- AUTO Inverter System supply

## Specification

### Connections:

Voltages $U_e$	98...132 VAC 196...264 VAC	3000VA/3000W 6000VA/6000W
Current $I_n$	Nominal current	30A
Frequency		45...65Hz
Safety		According to EN60950-1, Class I
Mains input connector	L N PE	3-pole 6mm <sup>2</sup> screw terminal
Inverter connectors	2L-3L 2N-3N or 5L-6L 5N-6N	2x2-pole 4-6mm <sup>2</sup> screw terminal
AC outputs connector	1L-4L 1N-4N 1PE-4PE	3x3-pole 6mm <sup>2</sup> screw terminal
	All connectors are located on rear panel	
Mains supply fuse	max 32A	External
Wiring	4-6 mm <sup>2</sup>	Halogen-free, 105°C

### Controls:

Manual bypass switch	Rotating switch K&N CA25 , 4 positions	max current 32A, short circuit max 450A
Distribution	1-3pcs of ZMTCB ZMTCB safety switches	On front panel, 1A-25A B or C curve

### Mechanical:

Dimensions	Height	6U (263mm)
	Width	14" (70mm)
	Depth	160mm (+ switch 30mm)
Weight	Module	2,26 kg
Enclosure	hot galvanized steel	IP20
Front plate painted		RAL7035
Finger protection		Polycarbonate plate in front of screw terminals

### Environmental:

Temperature range	Operating	-25°C...+50 °C
	Storage	-40°C...+70 °C
Grounding	6mm <sup>2</sup> screw terminal	1+3pcs on rear panel

## Operating and connecting the Manual bypass

### General

ZMTBP68000 series is manual bypass switch and/or AC-distribution unit for inverter systems. By manual bypass AC loads can be supplied directly from mains bypassing the inverter system. The inverter system can be also totally switched off by manual bypass switch. In normal operation mode (AUTO) inverter supply is distributed to loads via manual bypass. Also 1...3pcs of AC-distribution fuses can be included to ZMTBP unit (ZMTBP=manual bypass).

Three different variants are available:

1. ZMTBP68000 Manual bypass switch without AC-distribution
2. ZATDU68030 AC-distribution unit without manual bypass
3. ZMTBP68060 Manual bypass and AC-distribution unit

### Connecting the cables

Remove the finger protection polycarbonate plate by releasing two screws behind the module. Connect Mains in and AC load wires to screw terminals of ZMTBP. Make the strain relief by cable ties and fasten the finger protection plate to original position.

### Mains connection

Connect the mains cable to the screw terminals 1-3 (L N PE) according to pin configuration on the ZMTBP's rear panel via the strain relief. Fasten the cable by cable tie to the holder located beside the screw terminal. Use 1-phase power cable cross-section  $3 \times 0.75 \dots 6,0\text{mm}^2$ . The external maximum mains fuse is 32A. Make sure that both mains input and bypass output are switched off from sub-rack before connecting the ZMTBP.

### Loads connection

Connect the load cable to the screw terminals 8-16 (L N PE) according to pin configuration on the ZMTBP's rear panel via the strain relief. Fasten the cable by cable tie to the holder located beside the screw terminal. Use 1-phase power cable cross-section  $3 \times 0.75 \dots 6,0\text{mm}^2$ . The external maximum mains fuse is 32A. Make sure that both mains input and bypass output are switched off from sub-rack before connecting the ZMTBP.

### Connection the Bypass input and output

Use pre-assembled ZMTBP's 90cm bypass Mains in and AC out cables or similar 2m cables delivered with the static switch. Connect (if not pre-assembled) the "mains in" cable to the screw terminals 4-5 and "ac out" cable to the screw terminals 6-7 in the ZMTBP's rear panel via the strain relief. Fasten cables by cable tie to the holder located beside the screw terminal. Connect pre-assembled ZMTBP's "mains in" and "AC out" cables to static switch unit's mating connectors on front panel.

### Mounting the units

The module is mounted to the 19" sub-rack by 4pcs of M2,5 screws from the front panel.

## ZDTAC60000 Installation 19" and Wall Mounting Adapters for Inverters

### 19" Installation:

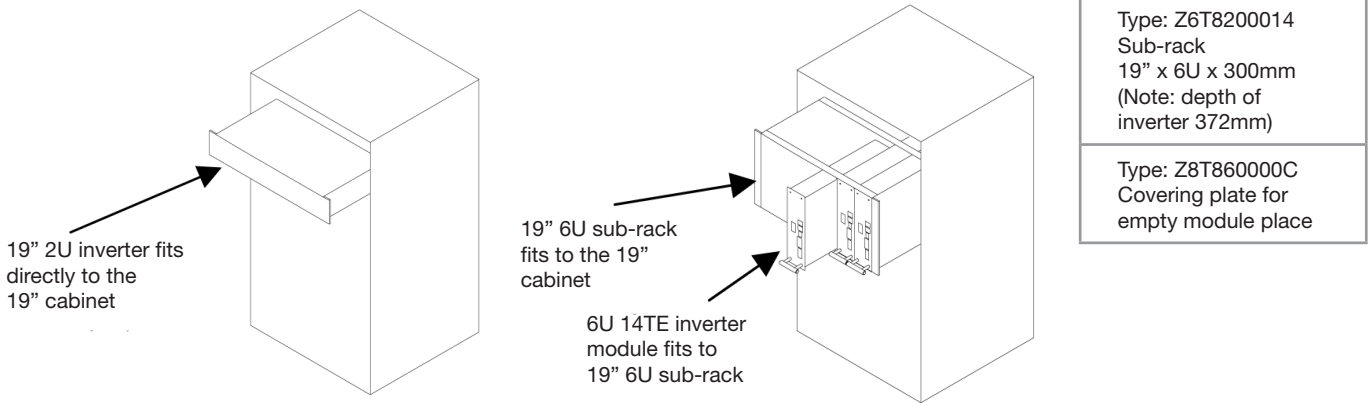

### Wall Mounting for 1...3 Modules:

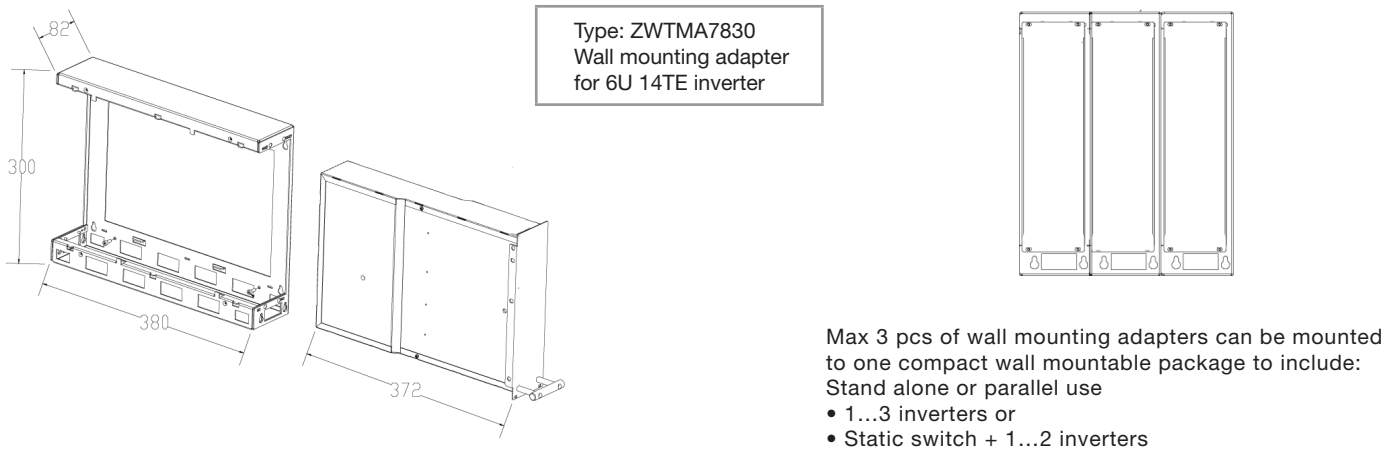

### Wall Mountable Sub-Racks for 1...6 Modules:

